

PRODUCT INFORMATION PACKET

Model No: 5KC37NN3544T

Catalog No: C1467

3/4 HP Aeration Fan Motor, 1 phase, 3600 RPM, 115/230 V, 56Z Frame, TENV
Aeration Fan Motors



Regal and Marathon are trademarks of Regal Beloit Corporation or one of its affiliated companies.
©2020 Regal Beloit Corporation, All Rights Reserved. MC017097E

REGAL



Nameplate Specifications

Output HP	0.75 Hp	Output KW	0.56 kW
Frequency	60 Hz	Voltage	115/230 V
Current	9.8,4.9 A	Speed	3450 rpm
Service Factor	1.25	Phase	1
Efficiency	71.7 %	Power Factor	0
Duty	Continuous	Insulation Class	B
KVA Code	K	Frame	56Z
Enclosure	Totally Enclosed Non Ventilated	Thermal Protection	AUTO
Ambient Temperature	40 °C	Drive End Bearing Size	6203
Opp Drive End Bearing Size	6203	UL	Recognized
CSA	Yes	CE	N

Technical Specifications

Electrical Type	Capacitor Start Induction Run	Starting Method	SM
Poles	2	Rotation	Counterclockwise/Clockwise
Mounting	Rigid Base	Motor Orientation	ANY
Drive End Bearing	BALL	Opp Drive End Bearing	Ball
Frame Material	Rolled Steel	Overall Length	11.26 in
Frame Length	6.62 in	Shaft Diameter	0.630 in
Shaft Extension	2.25 in		
Outline Drawing	52A109516P1	Connection Drawing	52A105383AA

This is an uncontrolled document once printed or downloaded and is subject to change without notice. Date Created:03/11/2020

52A109516

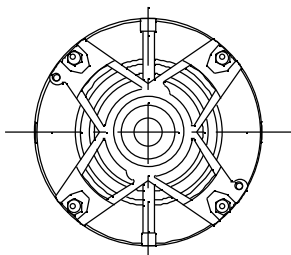
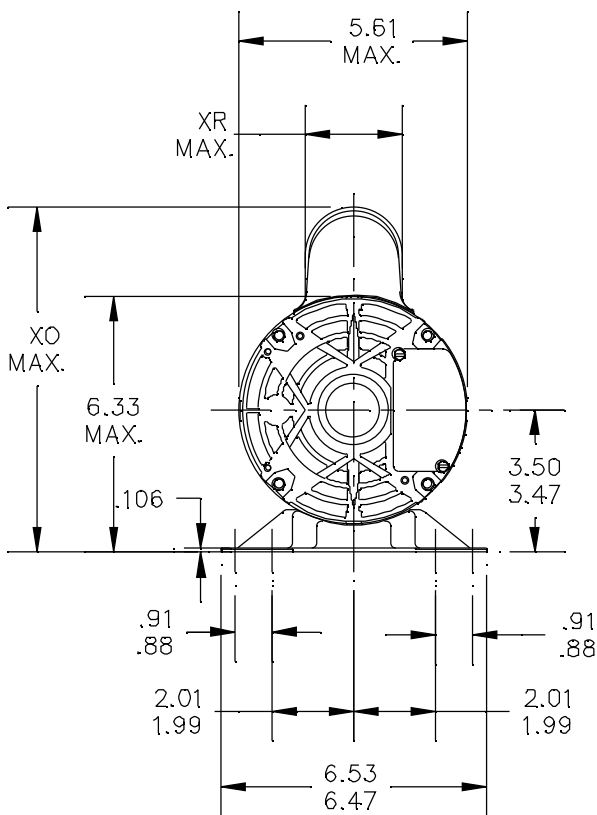

VIEW SHOWING P.E. (NO VENTS)

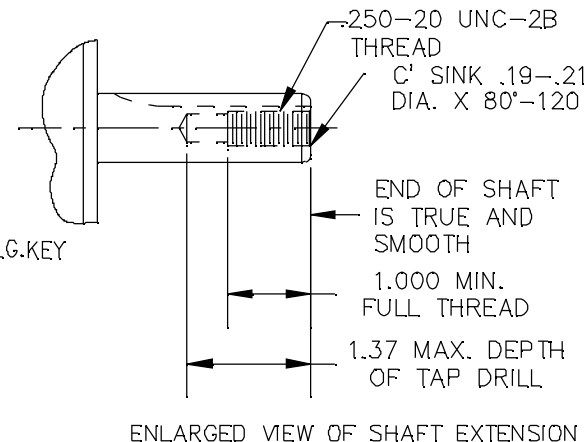
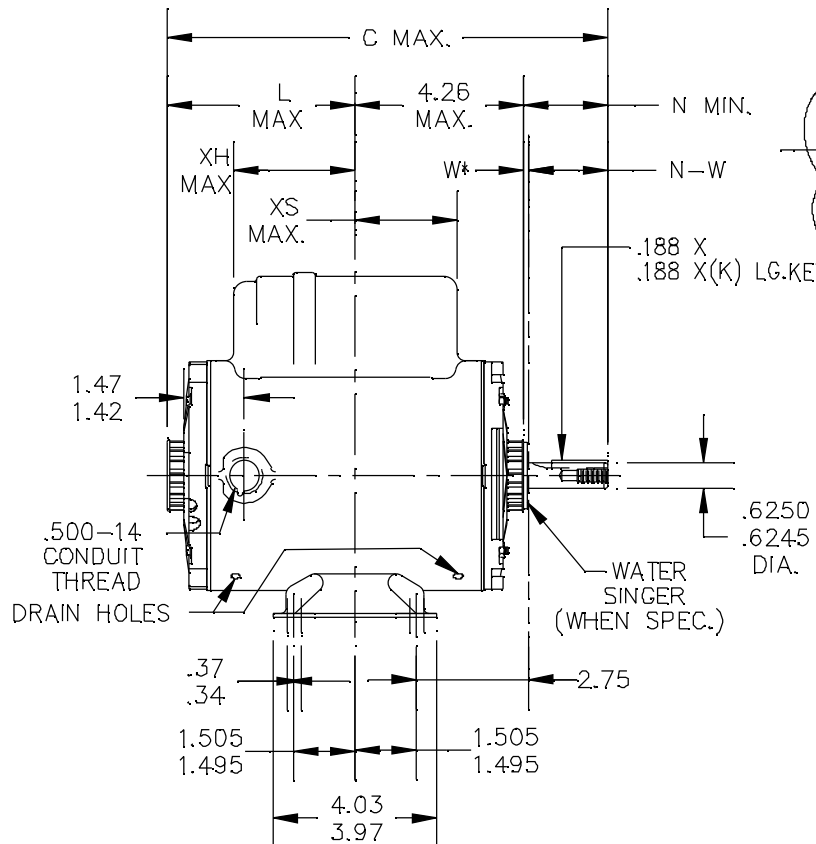

W* IS A CLEARANCE DUE TO VARIATION IN PARTS AND ASSEMBLY.

1	KC	37	56Z	11.26	1.62	4.63	2.25	2.38/2.19	2.99	2.68	7.85	1.60
P	TYPE	RBC SIZE	NEMA FR	C	K	L	N	N-W	XH	XS	XO	XR

				TOLERANCES UNLESS SPECIFIED		REGAL-BELOIT CORPORATION		DRAWN M.D.P 04/18/94			
				DEC.	INCHES			CHK			
				.X	±0.1	TITLE		SCALE 1=1			
4	REDRAWN IN DRAFT SIGHT NO CHANGES	PVR 10/16/12	PKG	.XX	±0.02	OUTLINE		REF			
3	TAPPING ADDED PER ISO9-1251	AMI 04/03/06		.XXX	±0.005	TENW - WELDED BASE		FMF			
2	CHG TO RBC FORMAT PER ISO5-1777	SUD 03/16/06		.XXXX	±0.0005	MAT'L.		PREV			
NO.	REVISION	BY & DATE	CHK	ANG	±1.0	FINISH					

THIS DRAWING IN DESIGN AND DETAIL IS OUR PROPERTY AND MUST NOT BE USED EXCEPT IN CONNECTION WITH OUR WORK ALL RIGHTS OF DESIGN AND INVENTION ARE RESERVED THIS IS AN ELECTRONICALLY GENERATED DOCUMENT - DO NOT SCALE THIS PRINT

RFP	CAD FILE	52A109516	SIZE	DRAWING NO.	REV.
DIST			A	52A109516	4

EITHER ROTATION, DUAL VOLTAGE, TYPE KC OR KH, WITH THERMAL PROTECTION

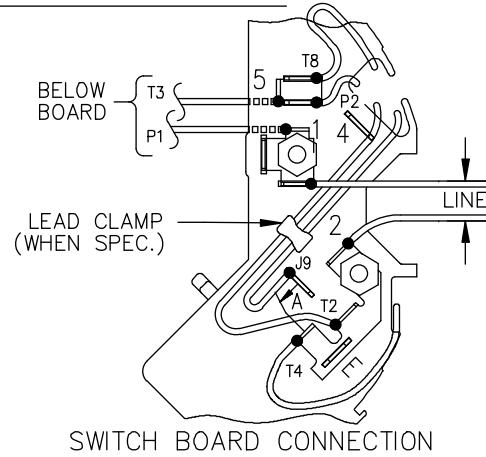

NOTE #1 - START CAP & J9 WHEN SPECIFIED (*). IF NO CAPACITOR (KH), CONNECT T5 DIRECTLY TO SWITCH (A). WHEN MORE THAN ONE CAPACITOR IS USED, CONNECT IN PARALLEL.

NOTE #2 - TO REVERSE ROTATION, INTER CHANGE RD(T8) AND BLK(J9-KC OR T5-KH) LEADS.

SWITCH REF. - 115D958AB	CONNECTION LABEL	CCW ROTATION: NP52X332051AA
		CW ROTATION: NP52X332051AC

NO.	REVISION	BY & DATE	CHK	TOLERANCES UNLESS SPECIFIED		FINISH	DRAWN M.D.P 06/29/87		
				DEC.	INCHES				
				.X	±0.1	REGAL-BELOIT CORPORATION TITLE CONNECTION DIAGRAM 30 FRAME SWITCH REDESIGN	CHK		
				.XX	±0.02		APPD M.D.P 03/26/96		
5	ADDED CONNECTION LABEL PER ECO-0030779	UD 02/06/13	PKG	.XXX	±0.005	MAT'L.	SCALE 1=1		
4	UPDATED PER ISO7-0150	MD 01/23/07		.XXXX	±0.0005		REF		
				ANG	±1.0	PREV			
THIS DRAWING IN DESIGN AND DETAIL IS OUR PROPERTY AND MUST NOT BE USED EXCEPT IN CONNECTION WITH OUR WORK. ALL RIGHTS OF DESIGN AND INVENTION ARE RESERVED. THIS IS AN ELECTRONICALLY GENERATED DOCUMENT - DO NOT SCALE THIS PRINT				RFP	CAD FILE	52A105383AA	SIZE A	DRAWING NO. 52A105383AA	REV. 5
				DIST					